

JVP

Twin screw pumps ZS

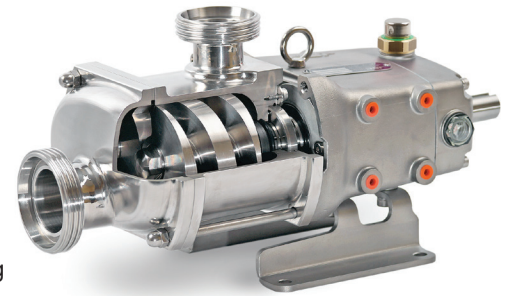

Description

ZS screw pumps offer a gentle pumping action. They are especially ideal for pumping high viscosities (for example dough). Also excellent for pumping fluids with changing viscosities (for example subsequent CIP cleaning). The seals can be easily exchange from the front side of the pump.

Your benefits

- Screw pump with twin screw technology
- Wetted components made of 316L stainless steel (Ra <0.8 µm)
- Pulsation-free and gentle pumping of shear sensitive media
- Double row angular contact ball bearings - ideal for high speeds
- Two different conveyor screw variants
- Optional: heating jacket as well as hardened conveyor screws and housing

Technical details

Max. flow	1660 l/min	Max. viscosity	1.000.000 mPas
Max. pressure	12 bar	Temperature range	-10 to +150 °C
Max. rotation speed	3000 rpm	Surface finish	Ra 0,8 µm
Connections	DIN, ISO, Tri-Clamp, SMS, RJT, Flange	Certifications	3A, EHEDG, FDA, EC 1935/2004, ATEX

Summary

Size	Motor/kW	Port(D1/D2)	Model	Screw pitch (mm)	Flow/rpm min-1	Max. pressure (bar)	Max. rotation speed (rpm)
100	3.7KW	2.5" x 2" 2" x 1.5"	ZS100-009-12	22	0,09	12	3000
	5.5/7.5KW	2.5" x 2" 2" x 1.5"	ZS100-013-08	34	0,13	8	3000
200	5.5/7.5KW	3" x 2.5" 2.5" x 2"	ZS-200-023-12	30	0,23	12	2500
	11/15/18.5KW	3" x 2.5" 2.5" x 2"	ZS200-032-08	45	0,32	8	2500
300	11/15/18.5KW	4" x 3" 3" x 2.5"	ZS300-055-12	40	0,55	12	2000
	22KW	4" x 3" 3" x 2.5"	ZS300-083-08	60	0,83	8	2000

JVP

Twin screw pumps ZS

Curve

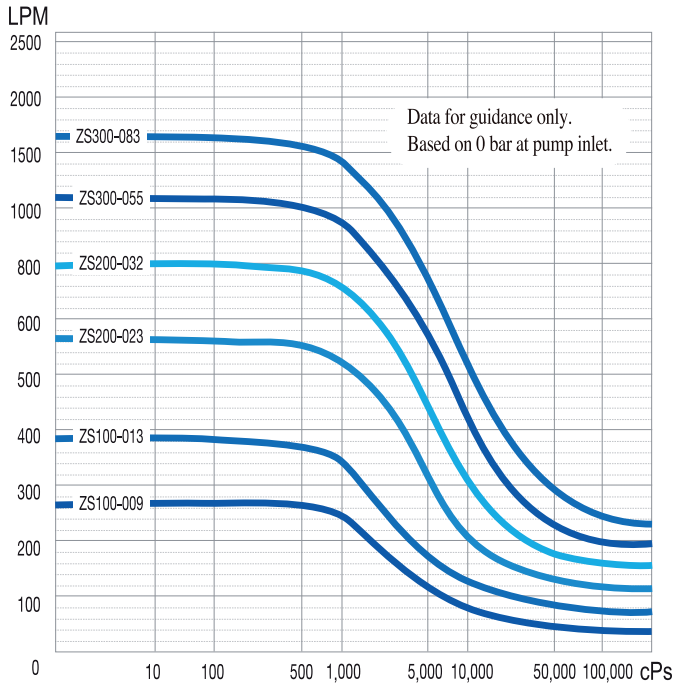

Dimensions

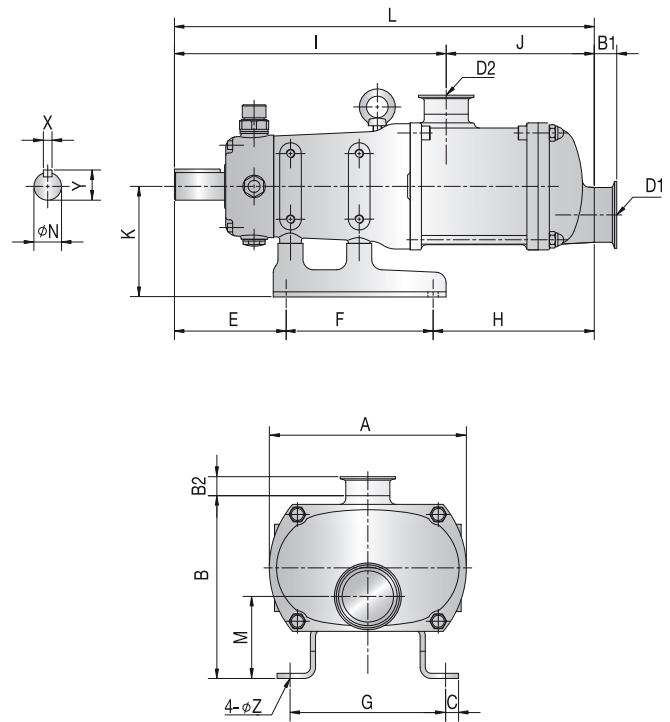

Model	Dimensions in mm												
	A	B	C	E	F	G	H	K	L	N	X	Y	Z
ZS100	115	168	12	96	124	134	141	101	360	22	8	25	9
ZS200	228	212	15	129	170	180	186	128	486	32	10	35	11
ZS300	315	297	21	158	215	242	245	181	618	45	14	49	13

All dimensions in mm (dimensions are approximate values)